

Case Study: Barcoding on Medical Devices: Benefits of barcodes and Consideration of barcode placement



The situation surrounding UDI

UDI is an acronym for Unique Device Identification. According to the IMDRF (*1), UDI is defined as a series of numeric or alphanumeric characters that is created through a globally accepted device identification and coding standard. It allows the unambiguous identification of a specific medical device on the market. In recent years, the attraction of UDI of medical device has been increasing. The IMDRF published “UDI Guidance: Unique Device Identification (UDI) of Medical Devices” in 2013. The guidance states that a globally harmonized and consistent approach to UDI is expected to increase patient safety and help optimize patient care by facilitating the:

- a. traceability of medical devices, especially for field safety corrective actions,
- b. adequate identification of medical devices through distribution and use.

In 2013, the US FDA released UDI rule amidst the increased importance of worldwide consistency. The main requirements of the UDI rule are as follows;

- a. Develop Unique Device Identifiers for all devices
- b. Place UDI on label and the device

- c. Submit data to US FDA’s Global UDI database

GS1 is accredited by the US FDA as one of the UDI Issuing Agencies, fulfilling conditions laid out by the UDI rule.

The legalization of UDI has been a broad worldwide trend. In EU, UDI rule was also released in May 2017.

Japan’s efforts to date

Ahead of the movement above, barcode labelling on medical devices has been promoted for many years in Japan.

Medical device industry issued guideline to promote barcode labelling in 1999. Reflecting on the movement of the industry, the Ministry of Health, Labour and Welfare (MHLW) officially decided to encourage barcode labelling on medical devices and published “Guidelines for Placing Standard Codes (Barcode Marking) on Medical Devices” in 2008. According to the survey on medical device by the MHLW in September 2016, the ratio of barcode labelling on sales package reached around 95%. On the other hand, the ratio of barcoding on medical device itself is not high. This is because the guideline by the MHLW deemed barcoding on medical device

*1 International Medical Device Regulators Forum is the forum which consists of the regulating authorities of nine countries,

itself to be a point for future consideration. Given the current situation, the JFMDA (Japan Federation of Medical Device Association) is now making efforts to improve the ratio of barcoding on medical devices. The JFMDA clearly states in its 2016 publication, “UDI Operation Manual for Medical Devices”, that it promotes barcoding on not only 1) inhalators, 2) defibrillators except AED, 3) infusion pumps, 4) syringe-type pumps, but also 5) medical devices that are used repeatedly after washing, sterilizing, and decontaminating, 6) transportable medical devices.

Efforts by GS1 Healthcare Japan

As mentioned above, although UDI has started to become mandatory worldwide; the regulations do not standardize the barcode placement. As a result, there are cases in which barcodes are put in positions inconvenient for medical staffs to scan (such as the back or bottom part of medical devices.)

In order to utilize barcodes in medical institutions to ensure traceability, barcode placement should be considered in light of ease of use for medical staffs. GS1 Healthcare Japan established a working group to discuss barcode placement on devices. In March 2017, the group released a report, “Barcoding on Medical Devices: Benefits of barcode and Consideration of barcode placement”. The report outlined the fields of application and benefit for medical staffs to utilize barcodes on medical devices. In addition to the benefits, the report showed basic points to consider regarding barcode placement and specific examples of barcode placement.

[Benefits]

- **Device registration** : Increasing efficiency in entering data into device registries
- **Appropriate allocation** : Appropriate inventory setting based on equipment utilization ratio.
- **Entering device information to medical records** : Reducing burden of nurses, improved accuracy of medical records
- **Invoices and insurance claims** : Prevention of incomplete medical billing and insurance claims.

- **Medical safety** : Preventing the use of incorrect device.
- **Device maintenance** : Ensuring regular maintenance by cross-checking with maintenance logs and generating notification of inspection dates.
- **Management of devices that are sterilized and used repeatedly** : Improving safety due to device-based traceability and accuracy of device assembly.
- **Management of medical device rentals** : Large reduction in administrative workload related to device rentals.
- **Rapid product identification and recall** : More accurate medical device information shared among medical institutions, device manufacturers, and suppliers, rapid identification and recall of defective devices.

[Basic points for barcode placement]

- Barcodes should be placed where users can view it easily when the device is used in medical institutions (avoid the back or bottom part of devices).
- Barcodes should be easily accessible for scanning, without hindering the use of devices.
- Barcodes should not affect the original functions, capabilities, or qualities of devices.
- Barcodes should not easily be unreadable due to blots, stains, break or deterioration.

Fig. 1 An example of a barcode position

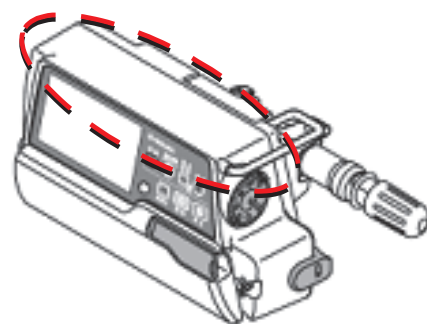

We hope this report will stimulate discussion about barcode placement on medical devices in Japan and facilitate progress in ensuring traceability through UDI.

GS1 Japan

3rd Fl. Place Canada, 7-3-37 Akasaka, Minato-ku, Tokyo 107-0052, JAPAN

T +81-3-5414-8520 F +81-3-5414-8529

E jan@dsri.jp

www.gs1jp.org